

## OTOMATİK AHŞAP TAS MENTEŞE YERİ AÇMA MAKİNESİ

LUNA - 2

## » Genel Özellikler

- 2 adet pratik malzeme dayama aparatı
- Pratik olarak ayarlanabilen derinlik mesafesi
- Ayarlanabilir ve eklenebilir gönye profil sistemi
- Frezeleme işlemi esnasında vidalama için referans delikleri açar
- İş parçası talaşını hava püskürtme ile temizleme
- Toplam ağırlık: 33 kg

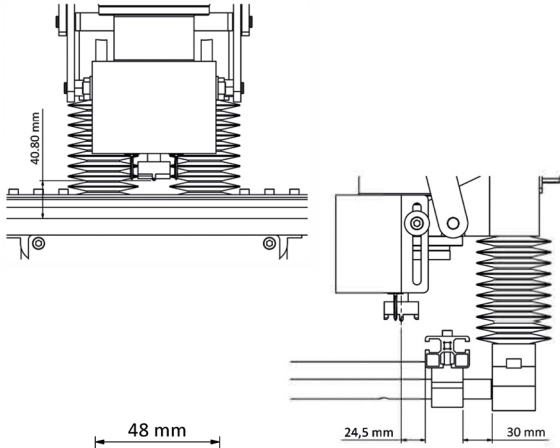
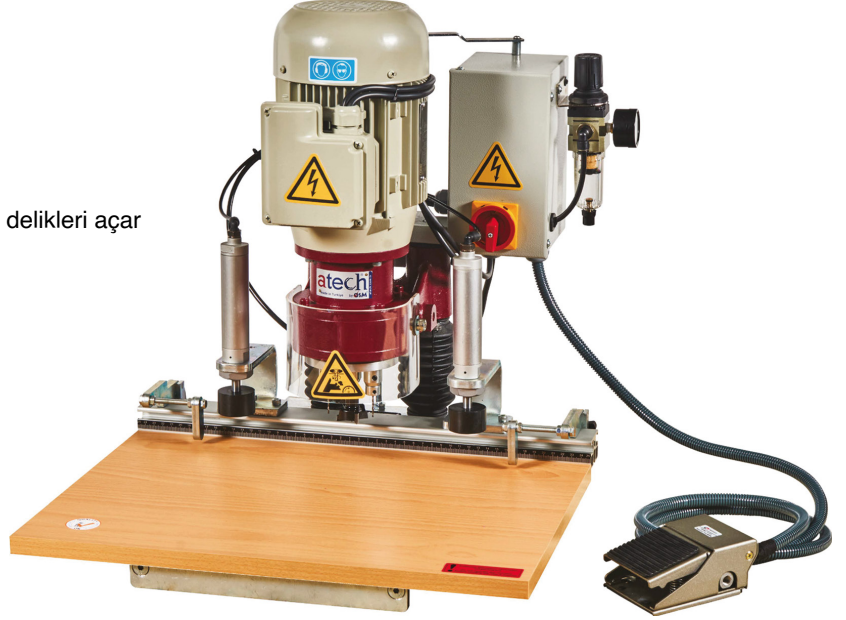

## ✓ Standart

- 1 ad. menteşe yeri açma freze bıçağı
- 2 ad. matkap ucu

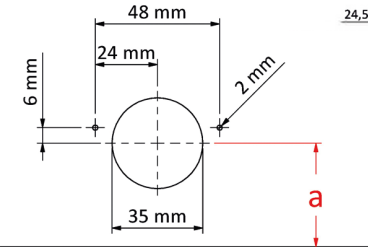

MOVING MITER

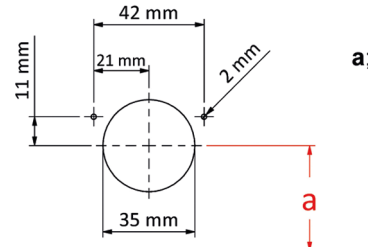

MOVING MITER

a; min = 24,5 mm  
max = 54,5 mm



## » Teknik Tablo

Motor	Paket Boyutu	Makine Boyutu	Makine Kg
0,55 kW 230 V, 50 Hz	W x L x H (cm) 55x55x55 cm	W x L x H (cm) 55x50x55 cm	33

